

Table of Contents

General Information	2
Functional Symbols.....	2
Model Codes	3
Technical Data	4
Flow Curves.....	5
Dimensions	6
Application Notes	7
Released Part Numbers.....	7

General Information

Features

- For subplate mounting mounting pattern to DIN 24 340, form D, ISO 5781, CETOP-RP 121H,
- Three adjustment elements:
 - Rotary knob
 - Sleeve with hexagon and protective cap
 - Lockable rotary knob with scale
- Five Pressure settings
- Optional check valve

General

XCG-2V-10 pressure valves are pilot operated pressure reducing valves, which are controlled from the secondary circuit.

They basically consist of main valve (1) with main spool insert (3) and pilot valve (2) with pressure adjustment element.

At rest, the valves are open, fluid can freely pass from port B to port A via the main spool insert (3).

Pressure present in port A acts upon the bottom side of the main spool. At the same time there is pressure acting on the ball (6) in the

pilot valve (2) via the orifice (4) on the spring-loaded side of the main piston (3) and via the port (5). Pressure from port A is also acting on the ball (6) via the orifice (7), control line (8), check valve (9) and orifice (10). According to setting of spring (11), pressure builds up in front of the ball (6), in port (5) and in spring chamber (12), holding the control piston (13) in the open position. Fluid can freely flow from port B to port A via main spool insert (3), until the pressure in port A exceeds the value set at spring (11) and opens the ball (6). The control piston (13) moves to closing position.

The desired reduced pressure is achieved, when

a balance between the pressure in port A and the pressure set at spring (11) is reached.

Pilot oil drain from spring chamber (14) to tank takes place externally via control line (15).

Free return flow from port A to B can be achieved by installing an optional check valve (16).

A pressure gauge connection (17) allows the reduced pressure in port A to be monitored

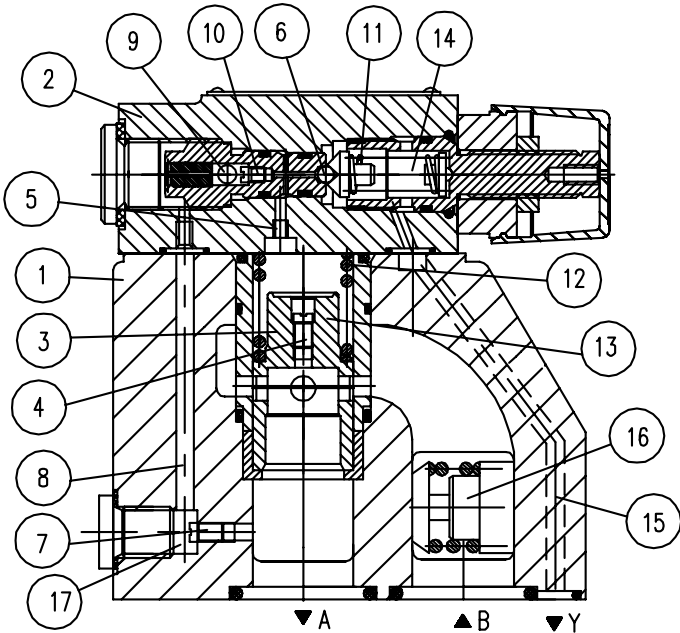

Functional Symbols

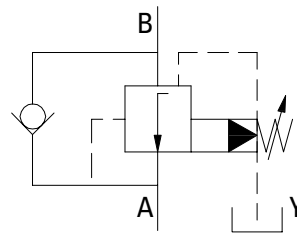

XCG

(with check valve)

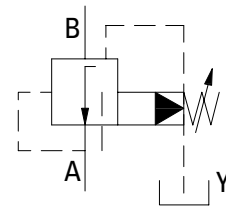

XG

(without check valve)

Series X(C)G2V-10 Model Code

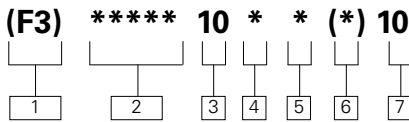

1 Seal Options

Blank – Nitrile, for Mineral oil
Anti-wear hydraulic oil (class
L-HFC), Water glycol (class
L-HFC)

F3 – Fluorocarbon seals,
for Phosphate Ester (class
L_HFD)

2 Two stage reducing valve, Gasket mounted, 350 bar rated

XCG2V – With reverse flow
check

XG2V – Without reverse flow
check

3 Size

ISO6264-10
NFPA/ANSI R10
10 - Cetop 10

4 Pressure Range

B – 50 bar

C – 100 bar

F – 200 bar

G – 315 bar

5 Adjustment

W – Wrench and cover

H – Knob

K – Lockable knob

6 External port thread

F – Metric

B – BSP

7 Design Number

10

Series X(C)G2V-10

Technical Data

Hydraulic Technical Data

Inlet pressure, port B	up to 315 bar
Outlet pressure, port A	10 to 315 bar
Drain, port Y	up to 315 bar
Maximum Flow	400 L/min.
Fluid	Fluid Mineral oils to (HL, HLP) DIN 51 524; Phosphate ester (HFD-R)
Fluid temperature range (°C)	-30 up to + 80 (with Nitrile seals) -20 to + 80 (with Fluorocarbon seals)
Fluid Viscosity range (mm²/s)	10 to 800
Fluid Cleanliness Level	ISO 19/17/14

Flow Curves

(measured at $\nu = 41$ mm²/s and $t = 50^\circ\text{C}$)

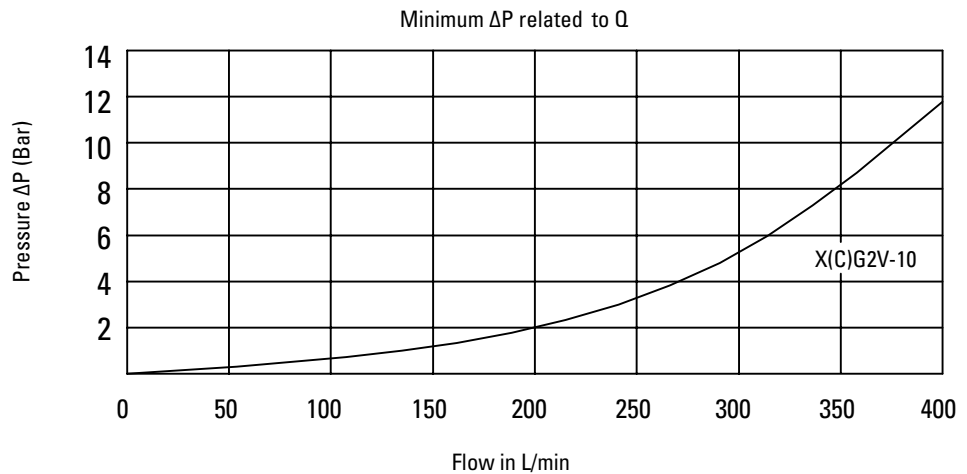
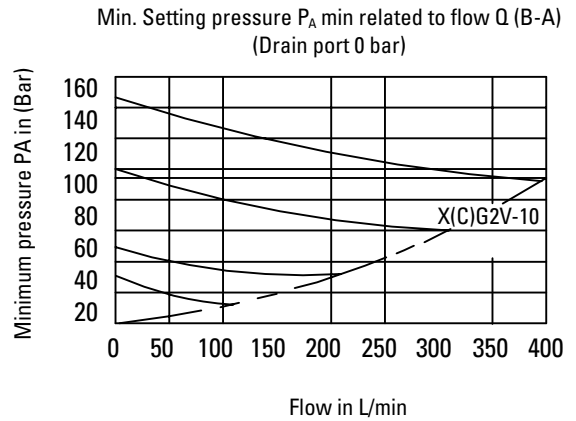
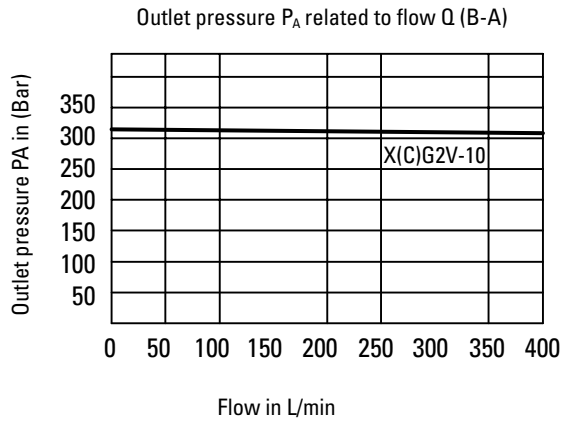

Series X(C) G2V-10

Flow Curves

(measured at $v = 41 \text{ mm}^2/\text{s}$ and $t = 50^\circ\text{C}$)

Pilot flow related to flow (B-A) and to pressure ΔP

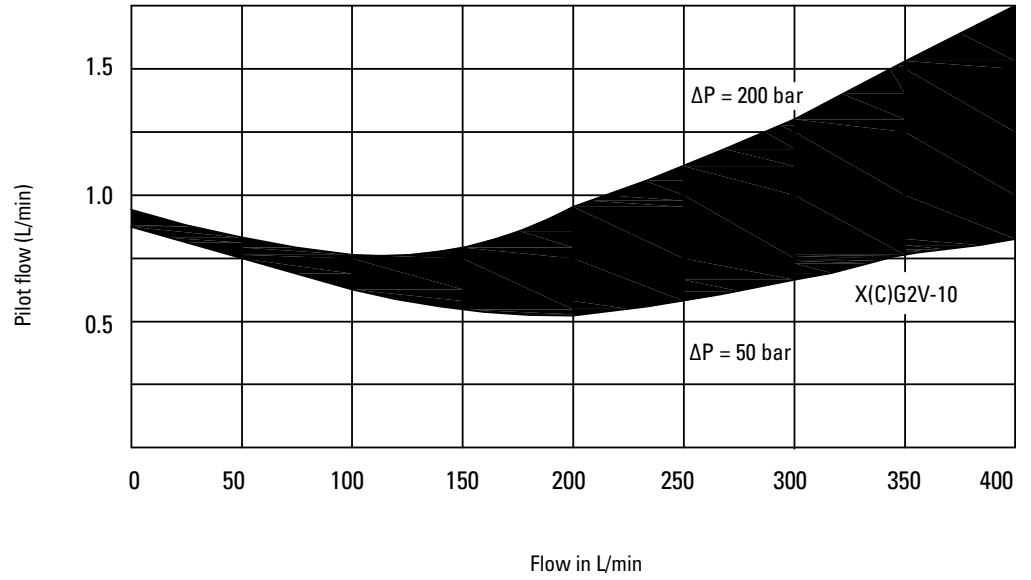

Pressure drop across check valve for reverse flow

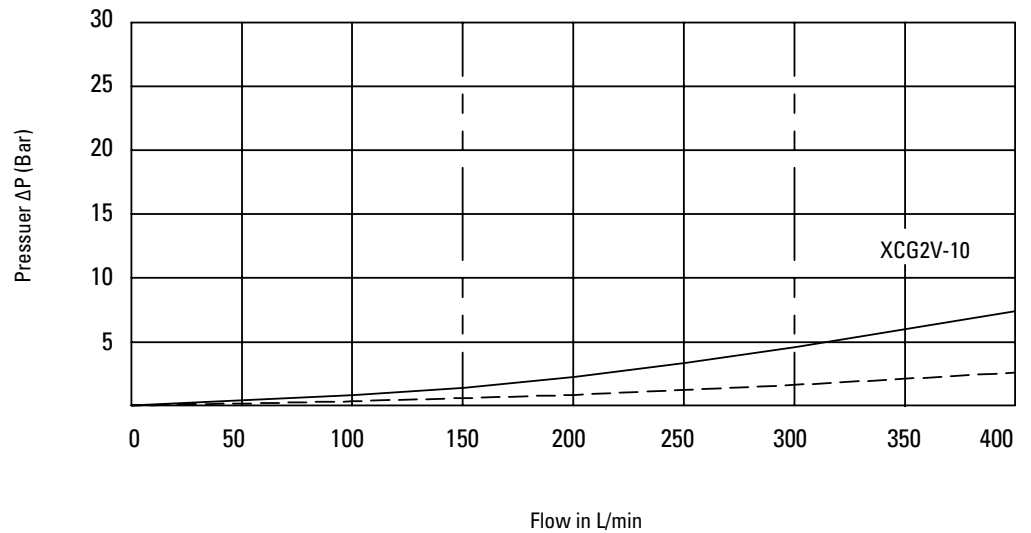

- ΔP of reverse flow with main stage closed
- - - - - ΔP of reverse flow with main stage fully open

Application Notes

1. The fluid must be filtered. The required fluid cleanliness level is ISO 19/17/14.
2. Surface finish of mating piece is required to 0.01/100mm.
3. Interface Seal Kit # for X(C)G2V-10
02-412610, Nitrile
02-412609, Fluorocarbon
4. Bolt kit for X(C)G2V-10
(6) M10x70 mm
(6) 3/8"-16x2-3/4" UNC,
MA=430Nm (317 lb-ft)
5. Mounting bolts must be to DIN 912-10.9 class, or Class 12.9 (ISO 898), or SAE Grade 8.

Released Part Numbers

Assembly Number	Model Code
02-412641	XCG2V-10CW-B-10
02-412642	F3-XCG2V-10CW-B-10
02-412643	XCG2V-10FW-B-10
02-412644	XG2V-10FW-B-10
02-412645	F3-XCG2V-10FW-B-10
02-412646	XCG2V-10GW-B-10
02-412647	XCG2V-10BW-B-10
02-412648	F3-XCG2V-10BW-B-10

Bold items have better lead-time

This page left intentionally blank

Eaton
Hydraulics Group USA
14615 Lone Oak Road
Eden Prairie, MN 55344
USA
Tel: 952-937-9800
Fax: 952-294-7722
www.hydraulics.eaton.com

Eaton
Hydraulics Group Europe
Route de la Longeraie 7
1110 Morges
Switzerland
Tel: +41 (0) 21 811 4600
Fax: +41 (0) 21 811 4601

Eaton
Hydraulic Group Asia Pacific
11th Floor Hong Kong New World Tower
300 Huaihai Zhong Road
Shanghai 200021
China
Tel: 86-21-6387-9988
Fax: 86-21-6335-3912