

EFX IO08 Input/Output Module

Output expansion module for EFX Controllers
 CANopen interface
 Surface electrostatically coated (cathodic immersion) 10...32V DC

Technical Data	8 Digital / PWM Outputs With Integrated Current Measurement
Housing	Die-cast zinc housing with 8 outputs and terminal chamber surface electrostatically coated (cathodic immersion), black
Dimensions (l x w x h)	227 x 77 x 39 mm (without cable gland)
Installation	Screw connection by means of 3 M5 x l screws to DIN 912 or DIN 7984
Connection	7-pole terminal strip with CAGE CLAMP® connection technology
Operating voltage and CAN bus	(2 x 2-pole/1 x 3-pole) 0.08...4 mm ² (AWG 28...AWG 12), nominal current 20 A Identical potentials can be linked using a jumper header (GND and UB potentials linked upon delivery)
Outputs CANin/CANout	Cable entry via M16 cable gland 8 x M12 connector (socket), 5-pole
Weight	1.2 kg
Outputs	8
can be configured as	digital, positive-switching (high side) PWM channel, or current-controlled channel
switching current per output	max. 4 A
total current	max. 16 A
Operating voltage U_B	10...32 V DC
Current consumption	≤ 50 mA (without external load at 24 V DC)
Operating temperature	- 40...85°C
Storage temperature	- 40...85°C
Protection	IP 67
Interface	CAN interface 2.0 B, ISO 11898
Baud rate	20 Kbits/s...1 Mbit/s (default setting 125 Kbits/s) (adjustable using hex-code switch in the terminal chamber or via the CANopen object directory)
Storage temperature	20 Kbits/s...1 Mbit/s (default setting 125 Kbits/s) (adjustable using hex-code switch in the terminal chamber or via the CANopen object directory)
Communication profile	CANopen, CiA DS 301 version 4, CiA DS 401 version 2.1
Node ID (default)	hex 20 (= dec 32) (adjustable using 2 hex-code switches in the terminal chamber or via the CANopen object directory)
Indication	1 LED green (PWR) 1 LED red (diagnosis, DIA) 8 LEDs yellow (status of the outputs)



Powering Business Worldwide

Connecting and operating elements

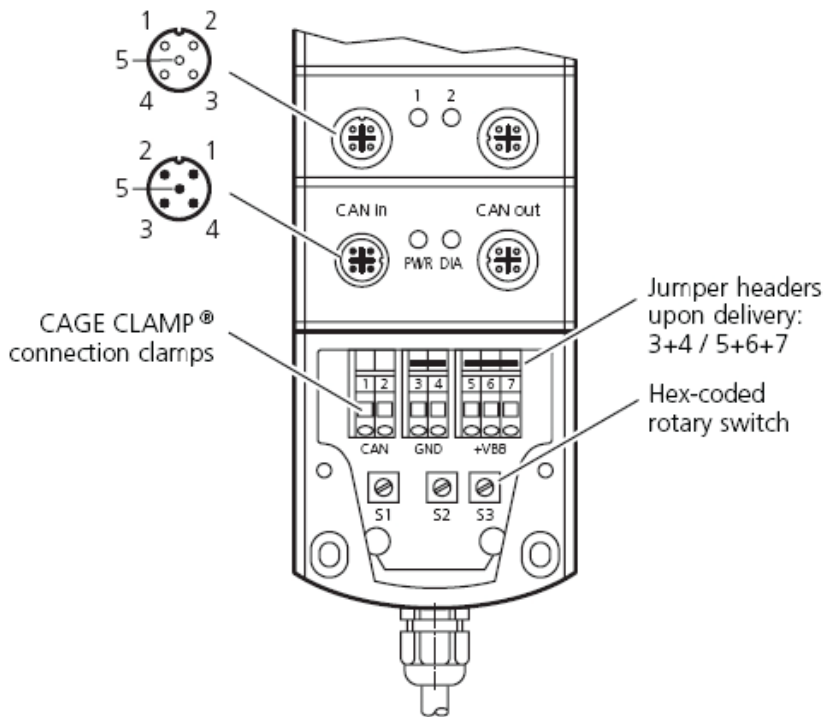

Hex-code switch coding

Switch	Position	Description
S1 Baud rate	0	1000 Kbits/s
	1	800 Kbits/s
	2	500 Kbits/s
	3	250 Kbits/s
	4	125 Kbits/s
	5	100 Kbits/s
	6	50 Kbits/s
	7	20 Kbits/s
	8...E	not defined
	F	adjustment via object directory (default)
S2	0...7	high nibble, e.g. 20 hex (= 32 dec)
Node ID _H	F	adjustment via object directory (default)
S3	0...E	low nibble, e.g. 20 hex (= 32 dec)
Node ID _L	F	adjustment via object directory (default)



Operating states (LEDs)

LED	Status	Description
PWR (green)	OFF	no supply voltage
	ON	module in stand-by mode
		CANopen status: PREOPERATIONAL / PREPARED
		outputs = OFF
	2.0 Hz	module active
		CANopen status: OPERATIONAL
		outputs are updated
DIA (red)	OFF	communication OK
	ON	communication disturbed
		• node guard / heartbeat error (if node guarding / heartbeat is activated)
		• no synch objects (if synch monitoring is activated)
OUT (yellow)	ON	binary output: output switched (ON) analogue output: PWM preset value ≠ 0 current preset value > 20

EFX IO08	Characteristics of the outputs
Digital Outputs	8 semiconductor outputs; short-circuit and overload protected Switching voltage 10...32 V DC Switching current max. 4 A Total current max. 16 A The current measurement of 2 channels each can be selected by means of the wire connections. The following channels are combined: 1+2, 3+4, 5+6, 7+8
PWM Outputs	With the configuration as "PWM output" two outputs each are combined (1+2, 3+4, 5+6, 7+8). PWM frequency 20...250 Hz Pulse duty factor 50...1000 % Resolution 1 % Switching current max. 4 A Total current max. 16 A
Current Outputs	With the configuration as "current-controlled output" two outputs each are combined (1+2, 3+4, 5+6, 7+8). PWM frequency 20...250 Hz Control range 20...1000 mA / 80...4000 mA Control resolution 1 mA / 4 mA (see control parameters) Setting resolution 1 mA Control characteristics can be set via the object directory (see control parameters) Accuracy $\pm 2\%$ FS Switching current max. 4 A Load resistance min. 12 / 3 Ω (at UB = 12 V DC) min. 24 / 6 Ω (at UB = 24 V DC)
Control parameters	By indicating the max. load current [mA] for each output pair the respective control or value range (1000 or 4000 mA) is automatically selected. In addition the P/I behaviour of the current controller can be parameterised for each output pair.
Free-wheel diode is integrated!	To avoid errors in the measuring result, no external free-wheel diode must be connected in parallel with the load in the "current-controlled output" operating mode.
Test standards and regulations	
Climatic test	Damp heat to EN 60068-2-30, test Db ($\leq 95\%$ rel. humidity, non-condensing), Salt mist test to EN60068-2-52, test Kb, severity level 3, Protection test to EN 60529
Mechanical resistance	Vibration to EN 60068-2-6, test Fc, Shock to EN 60068-2-27, test Ea, Bump to EN 60068-2-29, test Eb
Immunity to conducted interference	to ISO 7637-2, pulses 2, 3a, 3b, severity level 4, function state A to ISO 7637-2, pulse 5, severity level 1, function state A to ISO 7637-2, pulse 1, severity level 4, function state C
Immunity to interfering fields	directive 95/54/EC at 100 V/m (e1 type approval) and DIN EN 61000-6-2 :2001 (CE)
Interference emission	directive 95/54/EC (e1 type approval) and DIN EN 61000-6-4 :2001 (CE)

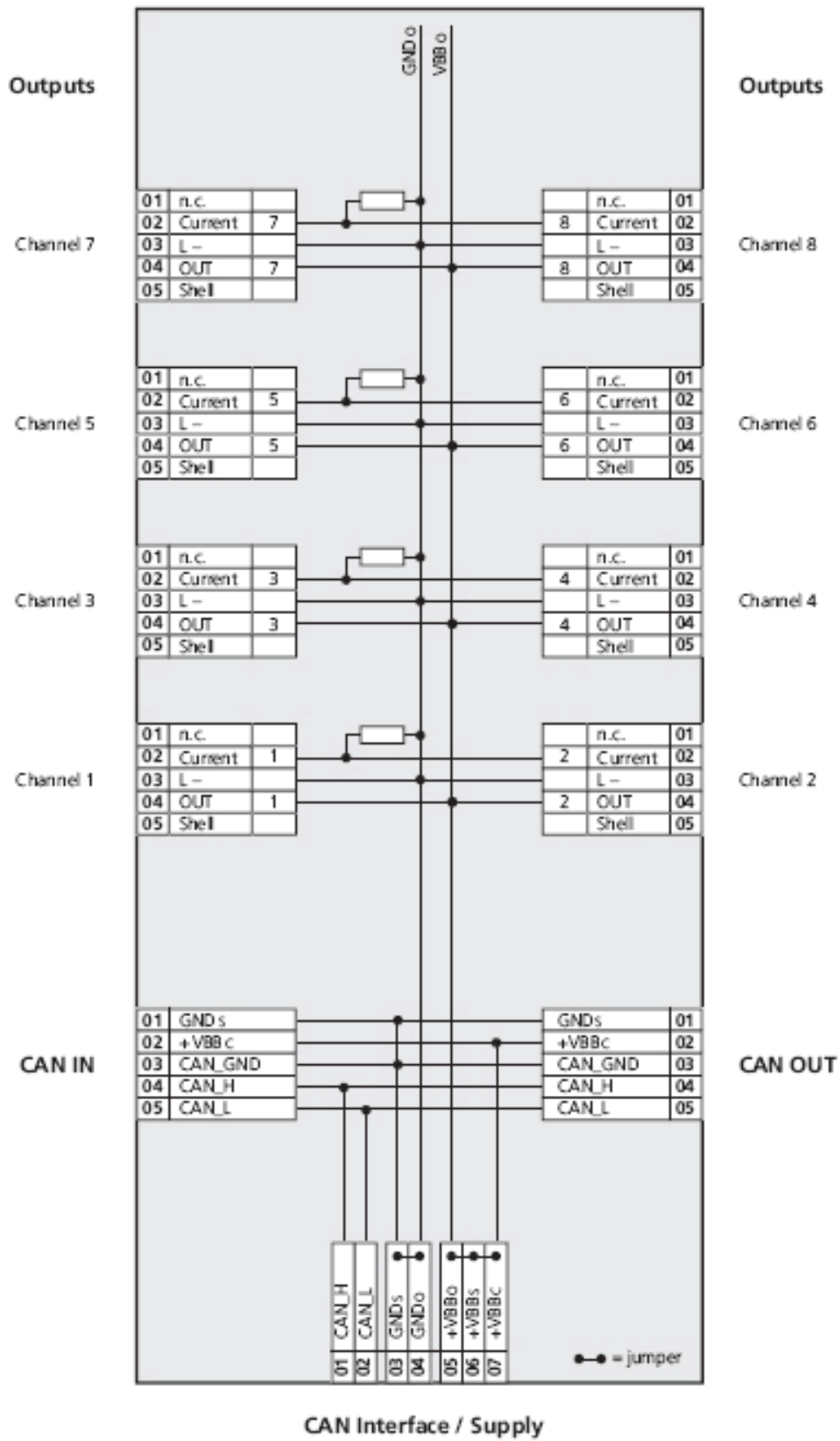

Abbreviations:

- CAN_H = CAN interface (high)
- CAN_L = CAN interface (low)
- GND_o = ground (output)
- GND_s = ground (module)
- PWM = output for pulse-width modulated signals
- VBB_c = operating voltage (via CANin/CANout plug)
- VBB_o = operating voltage (output)
- VBB_s = operating voltage (module)

Eaton
Hydraulics Group USA
14615 Lone Oak Road
Eden Prairie, MN 55344
USA
Tel: 952-937-9800
Fax: 952-294-7722
www.eaton.com/hydraulics

Eaton
Hydraulics Group Europe
Route de la Longeraie 7
1110 Morges
Switzerland
Tel: +41 (0) 21 811 4600
Fax: +41 (0) 21 811 4601

Eaton
Hydraulic Group Asia Pacific
11th Floor Hong Kong New
World Tower
300 Huaihai Zhong Road
Shanghai 200021
China
Tel: 86-21-6387-9988
Fax: 86-21-6335-3912