

Programmed with Eaton CONTROL F(x)™ Software to IEC 61131-3 Standard

2nd CAN interface for Gateway Function According to SAE J1939

Supply Voltage 10...32 V DC

Technical Data	Controller for the Implementation of a Central or Decentralized Electrohydraulic System
Housing	closed screened metal housing with flange fastening
Dimensions (H x W x D)	153 x 132 x 43 mm
Mounting	by means of 4 M5 x L screws to DIN 7500 or DIN 7984 mounting position horizontal or vertical to the mounting wall
Connection	55-pin connector, latched, protected against reverse polarity type AMP housing or Framatome AMP junior timer contacts, crimp connection 0.5/2.5 mm ²
Weight	0.95 kg
Inputs Can be configured as	8 4 digital; for positive sensor signals (low side); NAMUR; with diagnostic capability incl. 2 pulse inputs (max. 50 kHz) 4 analog; 0...10/32 V DC or 0/4...20 mA
Outputs Can be configured as Switching current per output Total current of all outputs	4 digital, positive switching (high side) PWM (PWM frequency 20...250 Hz) current-controlled (0.1...4 A) max. 4 A max. 16 A
Operating voltage UB Overvoltage Reset in case of undervoltage Auto save	10...30 V DC 36 V for $t \leq 10$ s at $UB \leq 9.5$ V at $UB \leq 9.0$ V
Current consumption	≤ 160 mA (without external load)
Housing temperature	-40...85°C (depending on the load)
Storage temperature	-40...85°C
Protection	IP 67 (for inserted plug with individually sealed cores e.g. ECEFX16 12S)
CAN interface 1 Baud rate Communication profile	CAN interface 2.0 B, ISO 11898 50 Kbits/s...1 Mbps/s (default setting 125 kBits/s) CANopen, CiA DS 301 version 3.0, CiA DS 401 version 1.4
CAN interface 2 Baud rate Communication profile	CAN interface 2.0 A/B, ISO 11898 50 Kbits/s...500 Kbits/s (default setting 125 kBits/s) SAE J1939
Serial interface Baud rate Topology Protocol	RS 232 C 9.6 Kbits/s, 19.2 Kbits/s, 28.8 Kbits/s point-to-point (max. 2 participants); master/slave connection predefined protocol (INTELHEX)
Node ID (default)	hex 20 (= dec. 32)

Abbreviations:

A = analog
 BH = binary high side
 BL = binary low side
 CAN_H = CAN interface
 CAN_L = CAN interface
 CYL = inputs for time period measurement
 FRQ = frequency inputs
 PWM = pulse-width-modulated signals
 RxD = serial interface (data received)
 TxD = serial interface (data transmitted)
 VBB_o = supply voltage outputs
 VBB_s = supply voltage sensors/module
 %IWx = IEC address for analog input
 %IX0.xx = IEC address for binary input
 %QX0.xx = IEC address for binary output



Powering Business Worldwide

EFX1612m**Technical Data**

Processor	CMOS microcontroller 16 bits C167C, pulse frequency 20 MHz		
Device monitoring	undervoltage monitoring, watchdog function, check sum test for program, and system monitoring for excess temperature		
Program memory	192 Kbytes flash, can be used by the user		
Data memory	64 Kbytes SRAM, 32 Kbytes flash, 3 Kbytes EEPROM		
Data memory (protected in case of power failure)	256 bytes (auto save memory)		
Status LED	two-color LED (red/green)		
Operating status (status LED) During the start-up or reset of the controller, the green and red LEDs light simultaneously, making the status LED appear orange in color.	LED Color	Status	Description
	–	constantly off	no supply voltage
	orange	for a short time on	initialization or reset checks
	green	5 Hz	no operating system loaded
	green	2.0 Hz	run
		constantly on	stop
	red	2.0 Hz	run with error
		constantly on	fatal error or stop with error
Electrical connection To guarantee the electrical interference protection of the controller, the housing must be connected to the ground of the vehicle!	Designation	Pin Number	Potential
	supply voltage	23	10...32 V DC (V_{BB_s})
	supply voltage outputs	05	10...32 V DC (V_{BB_o})
	ground	01	GND_s
	CAN interface 1	14/51	CAN_H
		32/50	CAN_L
		33/15	CAN_GND
	CAN interface 2	42/43	CAN_H
		44/45	CAN_L
		26/31	CAN_GND
	RS 232 interface (programming)	07 (TxD)	pin 02, PC D-Sub (9 pins)
		06 (RxD)	pin 03, PC D-Sub (9 pins)
		13 (GND)	pin 05, PC D-Sub (9 pins)
	“TEST” input		
	programming mode	24	10...32 V DC (V_{BB_s})
	operating mode	24	open

EFX 1612m**Characteristics of the Inputs/Outputs****Digital inputs**

(%IX0.0 / 0.8 / 1.0 / 1.8)
Can be configured as ...

- Digital inputs for positive switching sensor signals

switch-on level	0.7 U _B
switch-off level	0.4 U _B
input resistance	2.86 kΩ
input frequency	50 Hz
- NAMUR inputs; digital inputs with diagnostic capability when used with NAMUR sensors, supply voltage 5...25 V,

input resistance	2.86 kΩ
input frequency	50 Hz
- Diagnostic inputs (analog evaluation), digital inputs with diagnostic capability when an external resistor connection is used, corresponds to the NAMUR input

input resistance	2.86 kΩ
input frequency	50 Hz
- Frequency inputs; with diagnostic capability, evaluation with integrated comparator is used, corresponds to

input frequency 1	100 Hz...50 kHz (IN 0)
input frequency 2	100 Hz...50 kHz (IN 1)
input resistance	2.86 kΩ

Analog inputs

(%IW6...%IW9)
Can be configured as ...

- Voltage inputs

input voltage	0...10/32 V
resolution	10 bit
input resistance	50 kΩ
input frequency	50 Hz
- Current inputs

input current	0/4...20 mA
resolution	10 bit
input resistance	400 Ω
input frequency	50 Hz

Outputs

(%QX0.0 / 0.8 / 1.0 / 1.8)
Can be configured as ...

- Semi conductor outputs, positive switching (high side), short-circuit and overload protected

switching voltage	10...32 V DC
switching current	max. 4 A; total current max. 16 A
- PWM outputs; with diagnostic capability

PWM frequency	max. 250 Hz
PWM pulse ratio	1...99 %
resolution	depending on the PWM frequency
switching current	max. 4 A; total current max. 16 A
integrated pull-down resistor	(4.7 kΩ)
- Current-controlled outputs; with diagnostic capability

switching current	0.1...4 A; total current max. 16 A
setting resolution	1 mA
control resolution	5 mA
accuracy	± 2% FS

Input "TEST"

During the test mode (e.g. programming), the "TEST" connection must be connected to UB. For the "RUN" mode, the input must not be connected.
Input resistance 12 kΩ

Test Standards and Regulations**Humidity test to IEC 68-2-30**

≤ 90 % rel. humidity, non-condensing

Mechanical resistance

vibration to IEC 68-2-6, shock to IEC 68-2-27, bump to IEC 68-2-29

Immunity to conducted interference

to DIN 40839/part 1, pulses 1, 2, 3a, 3b (corresponds to ISO 7637) severity level 4, function state C, A
to DIN 40839/part 1, pulses 5 (corresponds to ISO 7637) severity level 1, function state C
to DIN 40839/part 3, pulses 1, 2, 3a, 3b (corresponds to ISO 7637) severity level 4, function state A

**EC declaration of conformity
Immunity to interfering fields
Interference emission**

according to directive EMC 89/336/EEC and LV 73/23/EEC
to EN 61000-6-2: 2001, at 100 V/m
to EN 61000-6-4: 2001

e1 type approval

according to directive 72/245/EWG, supplemented by directive 2006/28/EG

Railway specification

according to guideline BN 411 002 (DIN EN 50155, part 10.2)

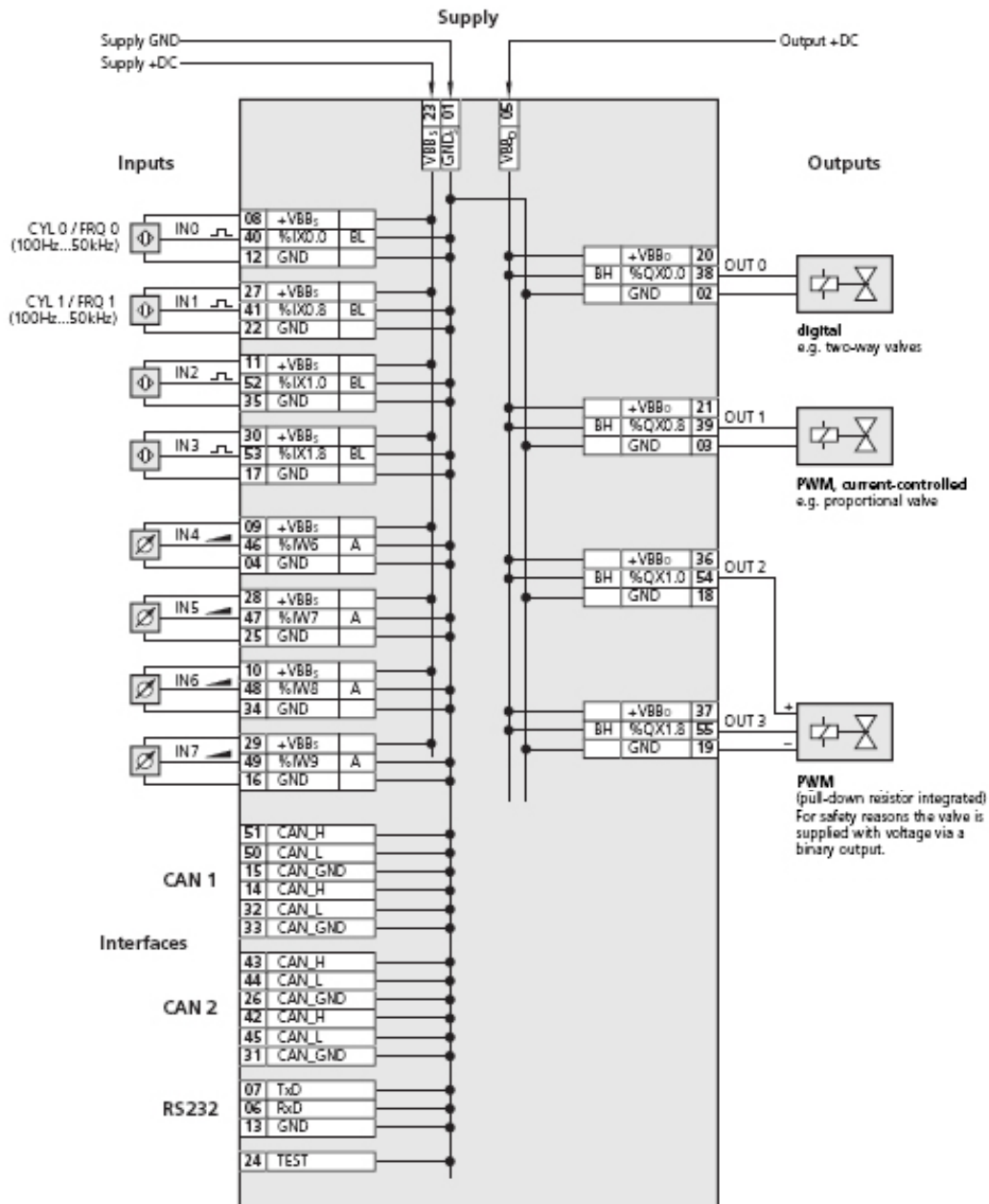

Eaton
Hydraulics Group USA
14615 Lone Oak Road
Eden Prairie, MN 55344
USA
Tel: 952-937-9800
Fax: 952-294-7722
www.eaton.com/hydraulics

Eaton
Hydraulics Group Europe
Route de la Longeraie 7
1110 Morges
Switzerland
Tel: +41 (0) 21 811 4600
Fax: +41 (0) 21 811 4601

Eaton
Hydraulic Group Asia Pacific
11th Floor Hong Kong New
World Tower
300 Huaihai Zhong Road
Shanghai 200021
China
Tel: 86-21-6387-9988
Fax: 86-21-6335-3912